

**Specification**

<b>Number of Poles</b>	8	
<b>Type</b>	ARS125-8P-F50	ARS125-8P-F60
<b>Frequency (± 2%)</b>	50 Hz	60 Hz
<b>Voltage (3ph.±5%)</b>	230V Δ / 400V Y	278V Δ / 480V Y
<b>Full Load Current</b>	7,7 A / 4,4 A	7,7 A / 4,4 A
<b>Input Power</b>	1600 W	1800 W
<b>Speed</b>	720 rpm	864 rpm
<b>Sound Pressure (L<sub>pA</sub>1m/2m)</b>	75 dB(A) / 70 dB(A)	78 dB(A) / 73 dB(A)
<b>Air Flow</b>	40.950 m <sup>3</sup> /h	41.500 m <sup>3</sup> /h
<b>Weight (varies by options)</b>	88 kg	

Air flow and sound pressure level (spl) are given for free blowing operation with inlet & outlet guard grids. SPL values at 1m are measured from side of the fan. SPL values at 2m are calculated by inverse square law.

**Performance**

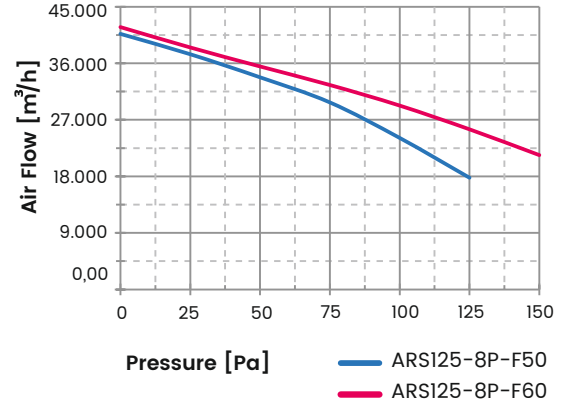

**Fan Dimensions**

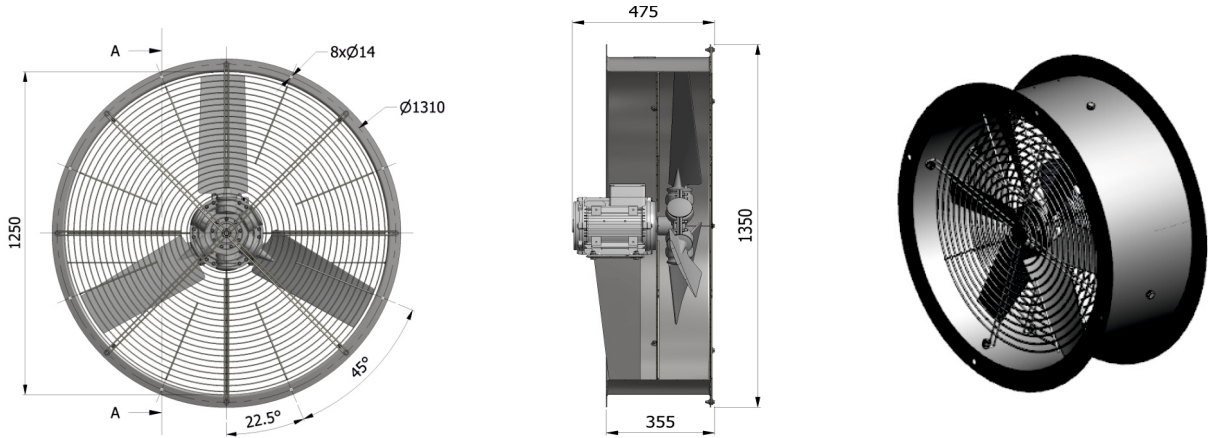

**Configuration**

<b>Motor Protection Class</b>	<input type="checkbox"/> IP55	<input type="checkbox"/> IP56	<input type="checkbox"/> IP65	<input type="checkbox"/> IP66
<b>Wings</b>	<input type="checkbox"/> GFR Polyamide		<input type="checkbox"/> Aluminium	
<b>Protection Grids</b>	<input type="checkbox"/> Rear		<input type="checkbox"/> Front	
<b>Color (housing,motor,grids)</b>	<input type="checkbox"/> RAL7031	<input type="checkbox"/> RAL7032	<input type="checkbox"/> RAL7033	<input type="checkbox"/> Other
<b>Operation Ambient (°C)</b>	<input type="checkbox"/> -25~+60	<input type="checkbox"/> -25~+70	<input type="checkbox"/> -40~+60	<input type="checkbox"/> -40~+70
<b>Corrosion Class</b>	<input type="checkbox"/> C3	<input type="checkbox"/> C4	<input type="checkbox"/> C5	Medium/High
<b>Thermal Protection</b>	<input type="checkbox"/> No		<input type="checkbox"/> Yes	

Thermal protection requires an external control unit or relay to operate.



### Specification

<b>Number of Poles</b>	12	
<b>Type</b>	ARS125-12P-F50	ARS125-12P-F60
<b>Frequency (± 2%)</b>	50 Hz	60 Hz
<b>Voltage (3ph.±5%)</b>	230V Δ / 400V Y	278V Δ / 480V Y
<b>Full Load Current</b>	3,5 A / 2,0 A	3,5 A / 2,5 A
<b>Input Power</b>	600 W	700 W
<b>Speed</b>	480 rpm	576 rpm
<b>Sound Pressure (L<sub>PA</sub>1m/2m)</b>	64 dB(A) / 59 dB(A)	68 dB(A) / 63 dB(A)
<b>Air Flow</b>	24.700 m <sup>3</sup> /h	24.500 m <sup>3</sup> /h
<b>Weight (varies by options)</b>	85 kg	

Air flow and sound pressure level (spl) are given for free blowing operation with inlet & outlet guard grids. SPL values at 1m are measured from side of the fan. SPL values at 2m are calculated by inverse square law.

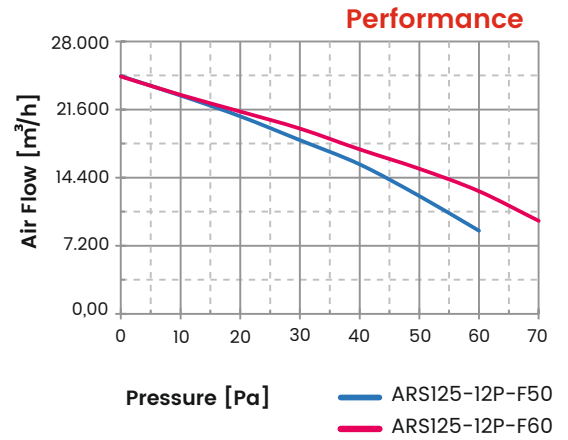

### Fan Dimensions

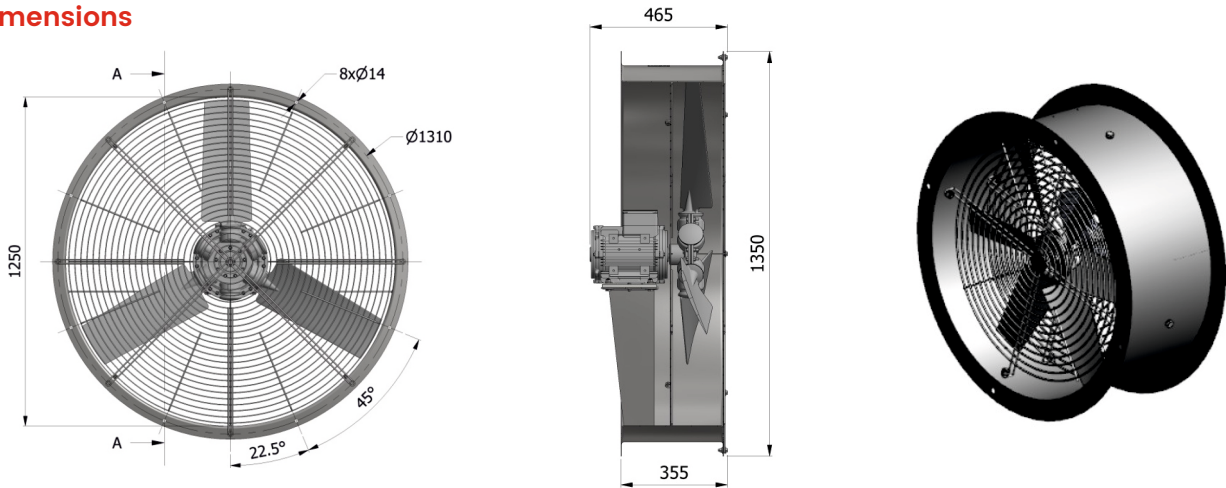

### Configuration

<b>Motor Protection Class</b>	<input type="checkbox"/> IP55	<input type="checkbox"/> IP56	<input type="checkbox"/> IP65	<input type="checkbox"/> IP66
<b>Wings</b>	<input type="checkbox"/> GFR Polyamide		<input type="checkbox"/> Aluminium	
<b>Protection Grids</b>	<input type="checkbox"/> Rear		<input type="checkbox"/> Front	
<b>Color (housing,motor,grids)</b>	<input type="checkbox"/> RAL7031	<input type="checkbox"/> RAL7032	<input type="checkbox"/> RAL7033	<input type="checkbox"/> Other
<b>Operation Ambient (°C)</b>	<input type="checkbox"/> -25~+60	<input type="checkbox"/> -25~+70	<input type="checkbox"/> -40~+60	<input type="checkbox"/> -40~+70
<b>Corrosion Class</b>	<input type="checkbox"/> C3	<input type="checkbox"/> C4	<input type="checkbox"/> C5	Medium/High
<b>Thermal Protection</b>	<input type="checkbox"/> No		<input type="checkbox"/> Yes	

Thermal protection requires an external control unit or relay to operate.

